

1 2 3 4 5 6 7 8  
 ALL DIMENSIONS IN MILLIMETRES  
 REMOVE ALL SHARP EDGES

1113 8  
 THIRD ANGLE PROJECTION  
 DO NOT SCALE DRAWING

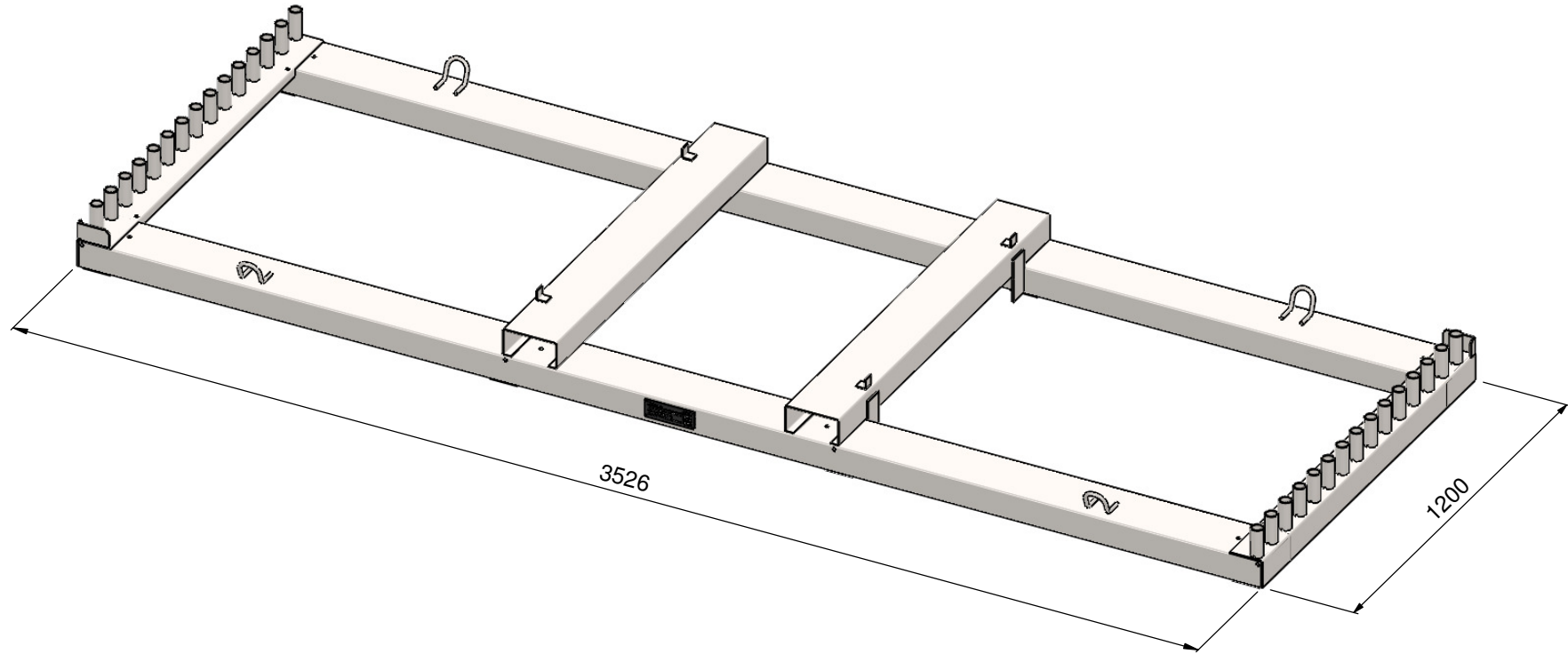

WEIGHT NOTE:  
 WEIGHT BEFORE GALVANISING = 90 Kg  
 WEIGHT GALVANISED = 95.5 Kg (ASSUMING 6% ADDED)

3	27/5/15	ISSUED FOR MANUFACTURE	GC		
2	19/6/14	ISSUED FOR MANUFACTURE	GC		
REV	DATE	DESCRIPTION	DRN	CHKD	APPR

TOLERANCES - UNLESS STATED OTHERWISE		TITLE:	
UNTOLERANCED DIMENSIONS	+/- 2mm	TRANSPORT PALLET 30	
CUTTING LENGTHS	+/- 2mm		
FABRICATION	UP TO 300mm	+/- 1mm	DRAWN
	UP TO 1000mm	+/- 2mm	
	1001mm & ABOVE	+/- 3mm	
	ANGULAR	+/- 1°	
MACHINING	+/- 0.2mm	FINISH:	HOT DIPPED GALVANISED
GAUGE	+/- 10%		
WEIGHT	+/- 10% (DUE TO MATERIAL PROPERTIES & TOLERANCES)		CARBON STEEL

NAME	SIGNATURE	DATE	MATERIAL:
G. CRICK		20/11/13	CARBON STEEL
CHK'D			



Drw / Stockcode No. **09055545** Revision **3**

WAS ZNDDE0100

THE COMPANY RETAIN THE RIGHT TO PERIODICALLY ALTER INFORMATION WITHIN THIS DRAWING SHEET AND WILL ATTEMPT TO NOTIFY ALL PARTIES CONCERNED OF ANY CHANGES AND THE INFORMATION ON THIS SHEET SHOULD NOT BE REPRODUCED WITHOUT THEIR WRITTEN CONSENT.