

1
ALL DIMENSIONS IN MILLIMETRES
REMOVE ALL SHARP EDGES

1037 8
THIRD ANGLE PROJECTION
DO NOT SCALE DRAWING

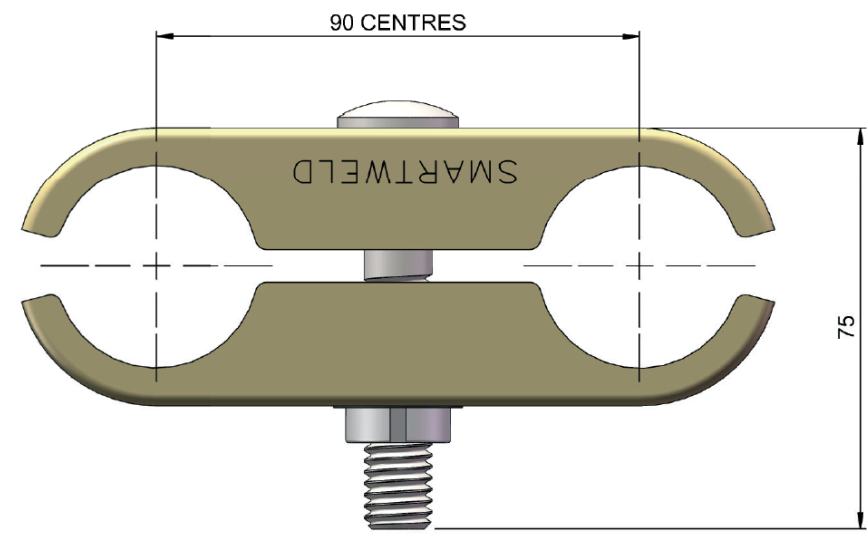
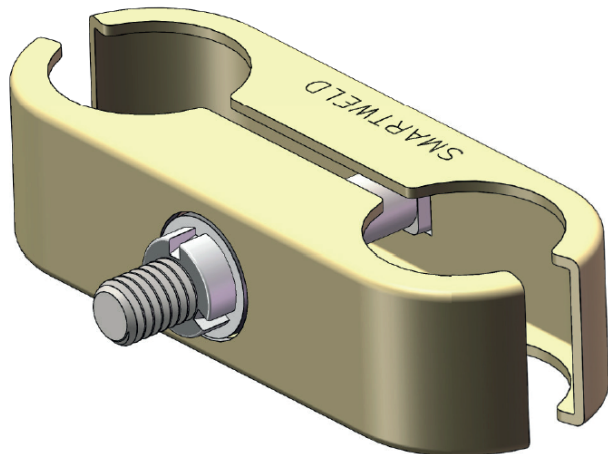

14	10/1/19	ISSUED FOR MANUFACTURE	GC	.	.
13	17/12/18	ISSUED FOR MANUFACTURE	GC	.	.
REV	DATE	DESCRIPTION	DRN	CHKD	APPR

TOLERANCES - UNLESS STATED OTHERWISE		
UNTOLERANCED DIMENSIONS	+/- 2mm	
CUTTING LENGTHS	+/- 2mm	
FABRICATION	UP TO 300mm	+/- 1mm
	UP TO 1000mm	+/- 2mm
	1001mm & ABOVE	+/- 3mm
	ANGULAR	+/- 1°
MACHINING	+/- 0.2mm	
GAUGE	+/- 10%	
WEIGHT	+/- 10% (DUE TO MATERIAL PROPERTIES & TOLERANCES)	

TITLE: HEAVY DUTY LOCKABLE COUPLER (GRIPLOCK)			
NAME	SIGNATURE	DATE	MATERIAL:
DRAWN G. CRICK		2/10/7	CARBON STEEL GRADE S275
CHK'D			
FINISH: ELECTRO GALVANISED COLOUR: GOLD			



Revision
14

Drw / Stockcode No.
08551430

THE COMPANY RETAIN THE RIGHT TO PERIODICALLY ALTER INFORMATION WITHIN THIS DRAWING SHEET AND WILL ATTEMPT TO NOTIFY ALL PARTIES CONCERNED OF ANY CHANGES AND THE INFORMATION ON THIS SHEET SHOULD NOT BE REPRODUCED WITHOUT THEIR WRITTEN CONSENT.