

ALL DIMENSIONS IN MILLIMETERS

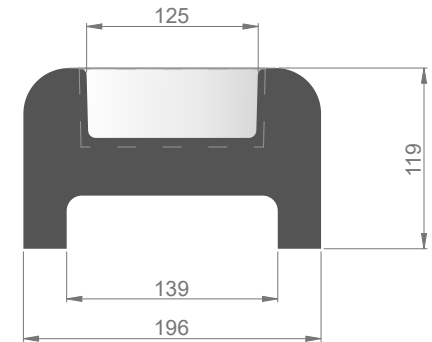
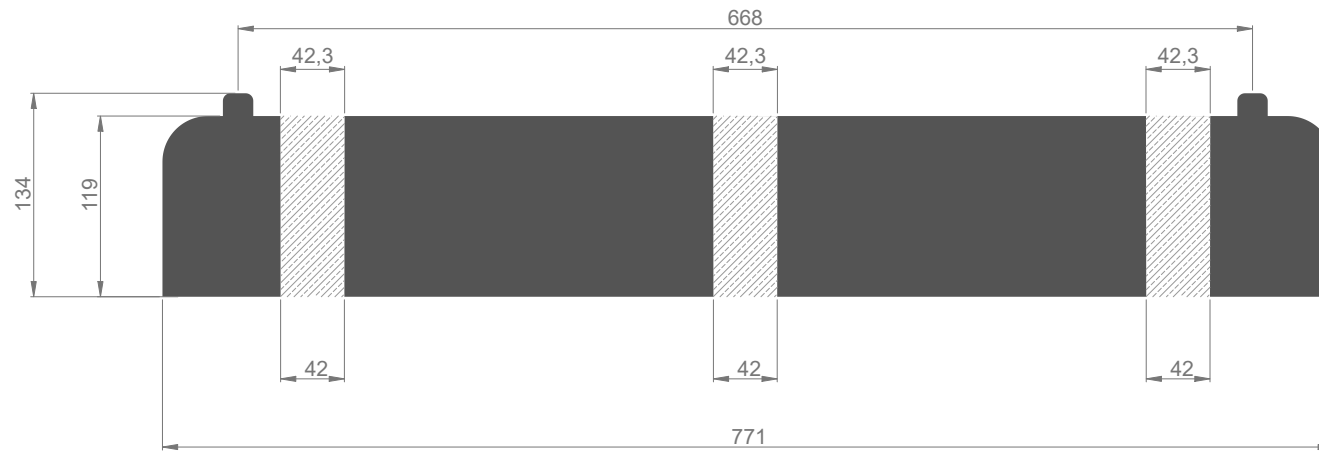
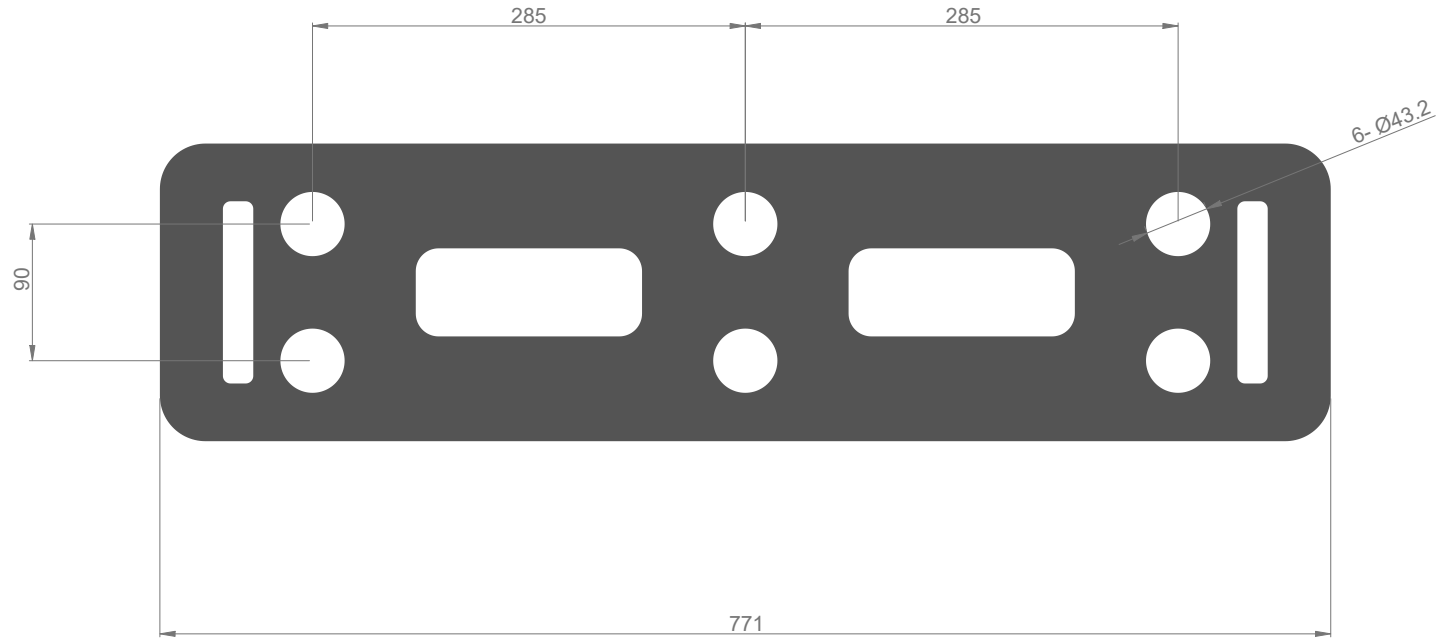

TOLERANCES - UNLESS STATED OTHERWISE		TITLE: Thermo-Plastic Foot (Std) CE		MATERIAL		Drw./ Stockcode No.:		Revision	
UNTOLERANCED DIMENSIONS		DRAWN		RECYCLD PLASTICS		12551030 CE		1	
CUTTING LENGTHS		CHKD		WEIGHT: 15.6 Kg		SCALE: 1:10		SHEET 1 OF 2	
MACHINING		FINISH:		none					
UP TO 300mm		NAME		DATE					
UP TO 1000mm		I. Rogowska-Czaja		10/07/23					
1001mm&ABOVE		A.Abramowicz		10/07/23					
ANGULAR									
± 10% (due to material properties and tolerance)									

The company retain the right to periodically alter information within this drawing sheet and will attempt to notify all parties concerned of any changes and the information on this sheet should not be reproduced without their written consent.