

1
2
3
4
5
6

ALL DIMENSIONS IN MILLIMETRES
REMOVE ALL SHARP EDGES

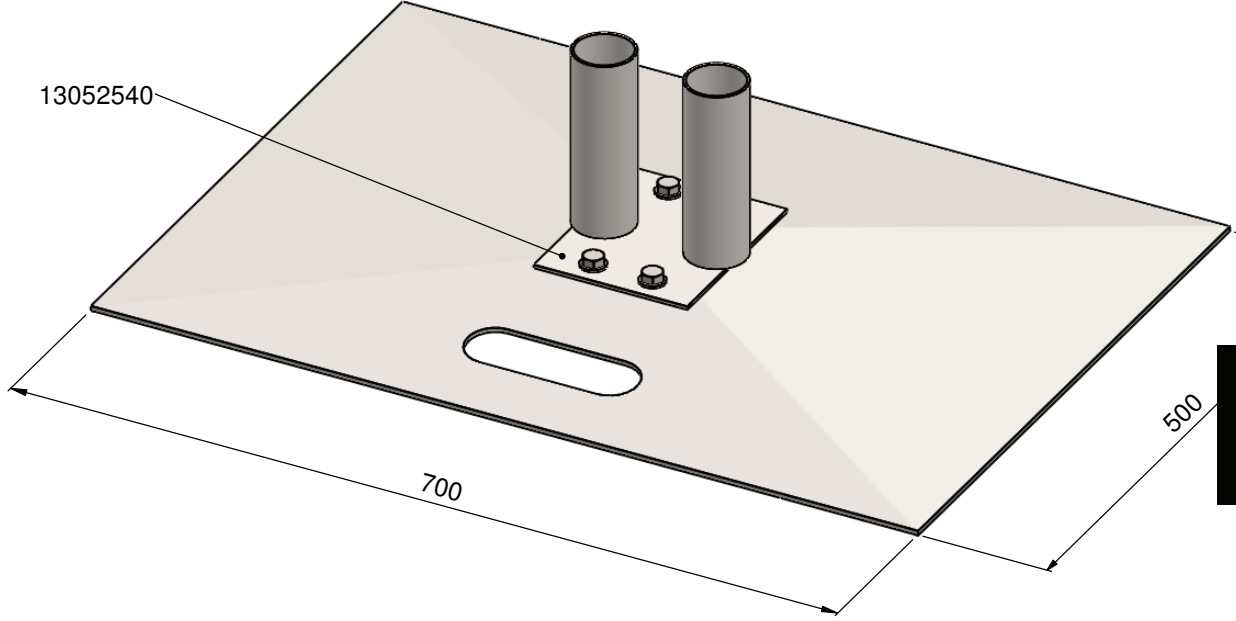

TOLERANCES - UNLESS STATED OTHERWISE		TITLE:
UNTOLERANCED DIMENSIONS	+/- 2mm	LARGE FO - EURO
CUTTING LENGTHS	+/- 2mm	
FABRICATION	UP TO 300mm	NAME
	UP TO 1000mm	SIGNATURE
	1001mm & ABOVE	DRAWN G. CRICK
	ANGULAR	CHKD
MACHINING	+/- 0.2mm	FINISH:
GAUGE	+/- 10%	HOT DIPPED GALVANISED
WEIGHT	+/- 10% (DUE TO MATERIAL PROPERTIES & TOLERANCES)	CARBON STEEL

WAS ZND533		TITLE:	
		LARGE FO - EURO	
		NAME	SIGNATURE
		DRAWN G. CRICK	
		CHKD	
		FINISH:	
		HOT DIPPED GALVANISED	
		CARBON STEEL	



Drw / Stockcode No. **13052550** Revision **4**

THE COMPANY RETAIN THE RIGHT TO PERIODICALLY ALTER INFORMATION WITHIN THIS DRAWING SHEET AND WILL ATTEMPT TO NOTIFY ALL PARTIES CONCERNED OF ANY CHANGES AND THE INFORMATION ON THIS SHEET SHOULD NOT BE REPRODUCED WITHOUT THEIR WRITTEN CONSENT.