



INSTYTUT TECHNIKI BUDOWLANEJ
PL 00-611 WARSZAWA
ul. Filtrowa 1
tel.: (+48 22) 825-04-71
(+48 22) 825-76-55
fax: (+48 22) 825-52-86
www.itb.pl



Member of



www.eota.eu

European Technical Assessment

**ETA-15/0323
of 01/06/2015**

General Part

Technical Assessment Body issuing the European Technical Assessment	Instytut Techniki Budowlanej
Trade name of the construction product	Q-MULTIFIX B15, Q-MULTIFIX B15 W and Q-MULTIFIX B15 T
Product family to which the construction product belongs	Bonded anchor with anchor rod made of galvanized steel or stainless steel for use in concrete
Manufacturer	Qube Solutions Group S.à.r.l. 81, rue de Luxembourg L-4391 Pontpierre Luxembourg
Manufacturing plant(s)	QUBE Manufacturing Plant 1
This European Technical Assessment contains	22 pages including 3 Annexes which form an integral part of this Assessment
This European Technical Assessment is issued in accordance with Regulation (EU) No 305/2011, on the basis of	Guideline for European Technical Approval ETAG 001, Edition April 2013 "Metal anchors for use in concrete – Part 1: Anchors in general and Part 5: Bonded anchors", used as European Assessment Document (EAD)

This European Technical Assessment is issued by the Technical Assessment Body in its official language. Translations of this European Technical Assessment in other languages shall fully correspond to the original issued document and should be identified as such.

Communication of this European Technical Assessment, including transmission by electronic means, shall be in full. However, partial reproduction may be made, with the written consent of the issuing Technical Assessment Body. Any partial reproduction has to be identified as such.

Specific Part

1 Technical description of the product

The Q-MULTIFIX B15, Q-MULTIFIX B15 W and Q-MULTIFIX B15 T are a bonded anchors (injection type) consisting of a injection mortar cartridge using an applicator gun equipped with a special mixing nozzle and threaded anchor rod of the sizes M8 to M24 made of:

- galvanized carbon steel,
 - stainless steel,
 - high corrosion resistant stainless steel,
- with hexagon nut and washer.

The threaded rod is placed into a drilled hole previously injected (using an applicator gun) with a mortar with a slow and slight twisting motion. The threaded rod is anchored by the bond between rod, mortar and concrete.

The threaded rods are available for all diameters with three type of tip end: a one side 45° chamfer, a two sides 45° chamfer or a flat. The threaded rods are either delivered with the mortar cartridges or commercial standard threaded rods purchased separately. The mortar cartridges are available in different sizes and types.

An illustration and the description of the products are given in Annex A1 to A4.

2 Specification of the intended use in accordance with the applicable European Assessment Document (EAD)

The performances given in Section 3 are only valid if the anchors are used in compliance with the specifications and conditions given in Annex B1 to B10.

The performances given in this European Technical Assessment are based on an assumed working life of the anchor of 50 years. The indications given on the working life cannot be interpreted as a guarantee given by the producer or the Technical Assessment Body, but are to be regarded only as a means for choosing the right products in relation to the expected economically reasonable working life of the works.

3 Performance of the product and references to the methods used for its assessment

3.1 Performance of the product

3.1.1 Mechanical resistance and stability (BWR 1)

The essential characteristic is detailed in the Annex C1 to C4.

3.1.2 Safety in case of fire (BWR 2)

No performance assessed.

3.1.3 Hygiene, health and the environment (BWR 3)

Regarding the dangerous substances clauses contained in this European Technical Assessment, there may be requirements applicable to the products falling within its

scope (e.g. transposed European legislation and national laws, regulations and administrative provisions). In order to meet the provisions of the Construction Products Regulation, these requirements need also to be complied with, when and where they apply.

3.1.4 Safety in use (BWR 4)

For Basic Requirement Safety in use the same criteria are valid as for Basic Requirement Mechanical resistance and stability (BWR 1).

3.1.5 Sustainable use of natural resources (BWR 7)

No performance assessed.

3.2 Methods used for the assessment

The assessment of fitness of the anchors for the intended use in relation to the requirements for mechanical resistance and stability and safety in use in the sense of the Basic Requirements 1 and 4 has been made in accordance with the ETAG 001 "Metal anchors for use in concrete", Part 1: "Anchors in general" and Part 5: "Bonded anchors", on the basis of Option 1 and 7.

4 Assessment and verification of constancy of performance (AVCP) system applied, with reference to its legal base

According to Decision 96/582/EC of the European Commission the system of assessment and verification of constancy of performance (see Annex V to Regulation (EU) No 305/2011) given in the following table applies.

Product	Intended use	Level or class	System
Metal anchors for use in concrete	For fixing and/or supporting to concrete structural elements (which contributes to the stability of the works) or heavy units	-	1

5 Technical details necessary for the implementation of the AVCP system, as provided for in the applicable European Assessment Document (EAD)

Technical details necessary for the implementation of the AVCP system are laid down in the control plan deposited at Instytut Techniki Budowlanej.

For type testing the results of the tests performed as part of the assessment for the European Technical Assessment shall be used unless there are changes in the production line or plant. In such cases the necessary type testing has to be agreed between Instytut Techniki Budowlanej and the notified body.

Issued in Warsaw on 01/06/2015 by Instytut Techniki Budowlanej

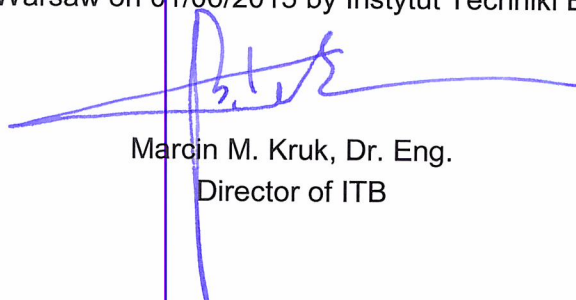

Marcin M. Kruk, Dr. Eng.
Director of ITB

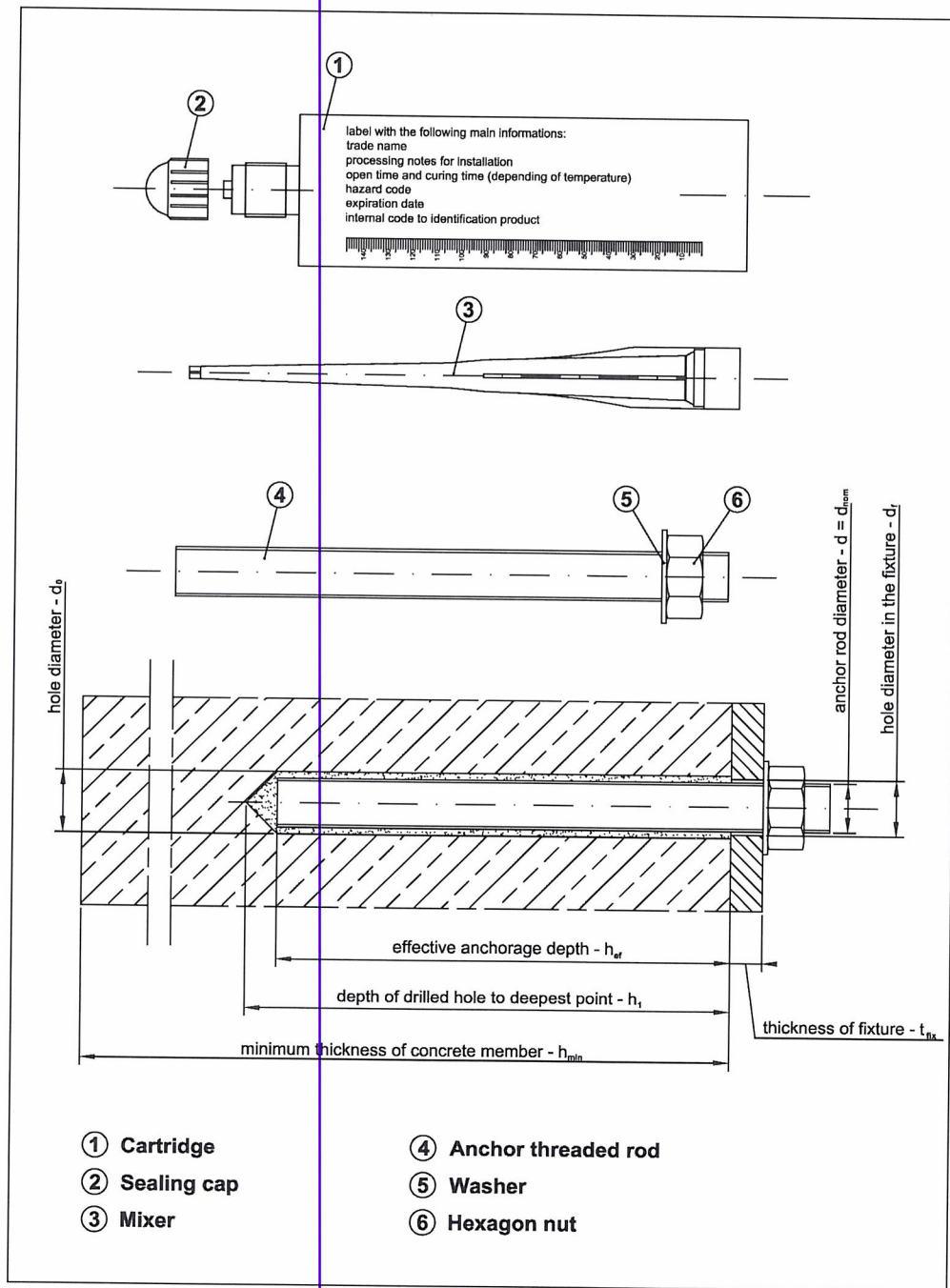

Q-MULTIFIX B15, Q-MULTIFIX B15 W and Q-MULTIFIX B15 T

Characteristic of the product

Annex A1
 of European
 Technical Assessment
 ETA-15/0323

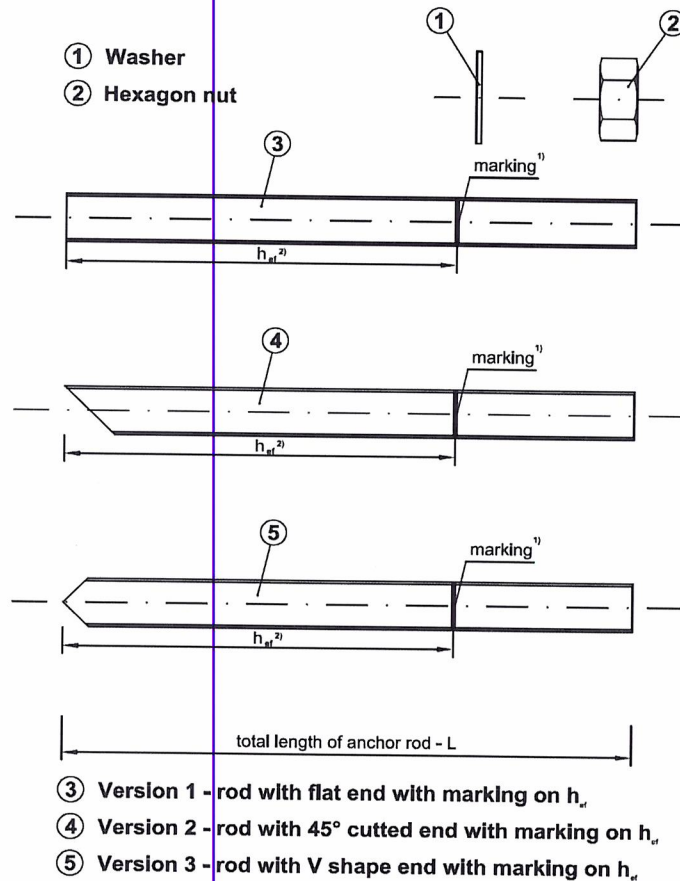

- 1) Marking according to clause 2.1.2 of ETAG 001 – Part 5
2) Effective anchorage depth according to Table A1

Table A1: Anchor threaded rod dimensions

Size	d [mm]	$h_{ef,min}$ [mm]	$h_{ef,max}$ [mm]
M8	8	60	160
M10	10	70	200
M12	12	80	240
M16	16	100	320
M20	20	120	400
M24	24	145	480

Q-MULTIFIX B15, Q-MULTIFIX B15 W and Q-MULTIFIX B15 T

Anchor rod types and dimensions

Annex A2
of European
Technical Assessment
ETA-15/0323

Table A2: Threaded rods			
Part	Designation		
	Steel, zinc plated $\geq 5 \mu\text{m}$ acc. to EN ISO 4042	Stainless steel	High corrosion resistance stainless steel (HCR)
Threaded rod	Steel, property class 4.8 to 12.9, acc. to EN ISO 898-1	Material 1.4401, 1.4571 acc. to EN 10088; property class 70 and 80 (A4-70 and A4-80) acc. to EN ISO 3506	Material 1.4529, 1.4565, 1.4547 acc. to EN 10088; property class 70 acc. to EN ISO 3506
Hexagon nut	Steel, property class 4 to 12, acc. to EN 20898-2; corresponding to anchor rod material	Material 1.4401, 1.4571 acc. to EN 10088; property class 70 and 80 (A4-70 and A4-80) acc. to EN ISO 3506	Material 1.4529, 1.4565, 1.4547 acc. to EN 10088; property class 70 acc. to EN ISO 3506
Washer	Steel, acc. to EN ISO 7089; corresponding to anchor rod material	Material 1.4401, 1.4571 acc. to EN 10088; corresponding to anchor rod material	Material 1.4529, 1.4565, 1.4547 acc. to EN 10088; corresponding to anchor rod material
<p>Commercial standard threaded rods (in the case of rods made of galvanized steel – standard rods with property class ≤ 8.8 only), with:</p> <ul style="list-style-type: none"> – material and mechanical properties according to Table A2, – confirmation of material and mechanical properties by inspection certificate 3.1 according to EN-10204:2004; the documents shall be stored, – marking of the threaded rod with the embedment depth. <p>Note: Commercial standard threaded rods made of galvanized steel with property class above 8.8 are not permitted in some Member States.</p>			
Table A3: Injection mortars			
Product	Composition		
Q-MULTIFIX B15 Q-MULTIFIX B15 W Q-MULTIFIX B15 T (two component injection mortars)	Additive: quartz Bonding agent: vinyl ester resin styrene free Hardener: dibenzoyl peroxide		
Q-MULTIFIX B15, Q-MULTIFIX B15 W and Q-MULTIFIX B15 T			Annex A3 of European Technical Assessment ETA-15/0323
Materials			

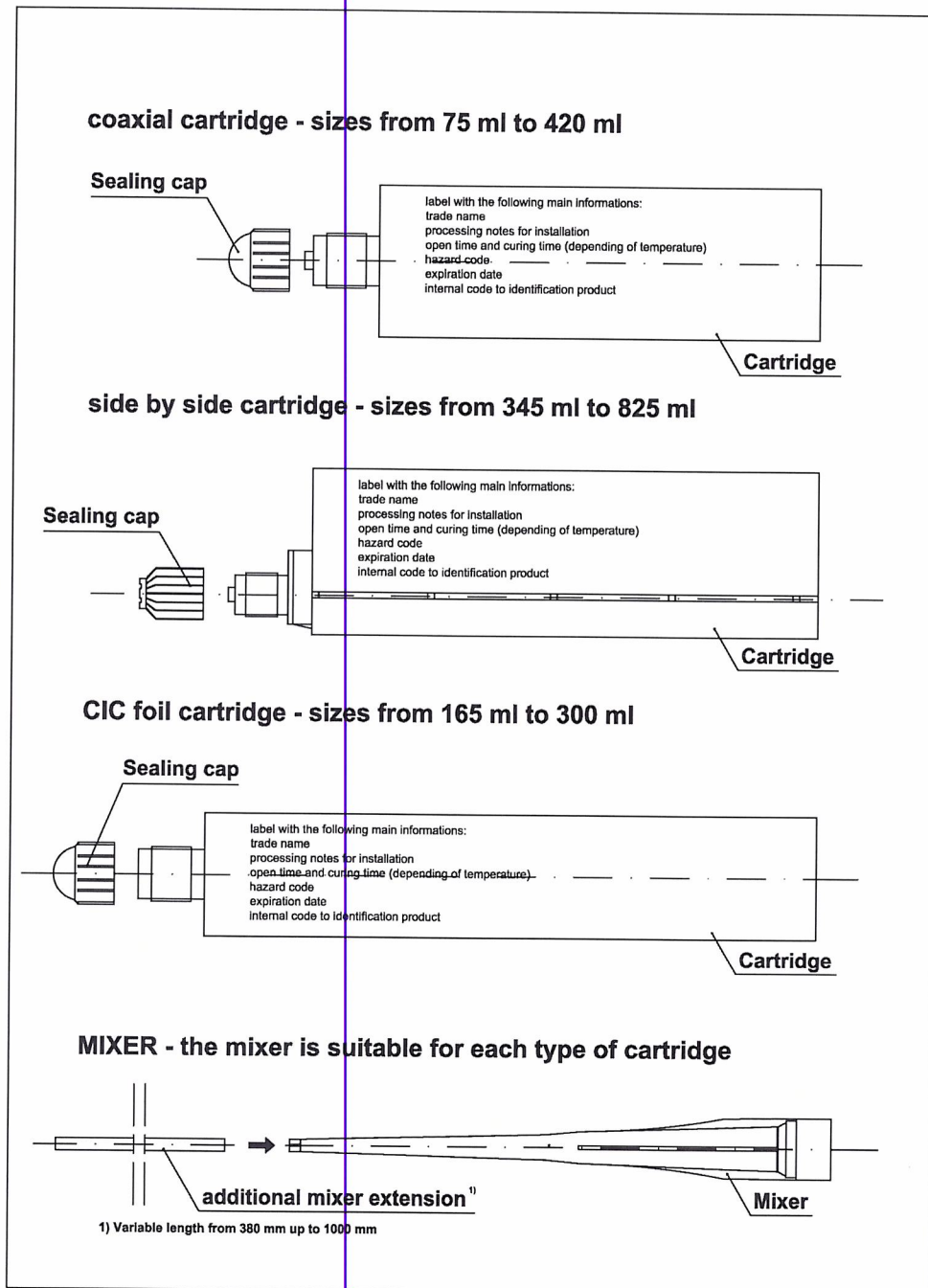

Q-MULTIFIX B15, Q-MULTIFIX B15 W and Q-MULTIFIX B15 T

Cartridge types and sizes

Annex A4
 of European
 Technical Assessment
 ETA-15/0323

SPECIFICATION OF INTENDED USE

Use:

The anchors are intended to be used for anchorages for which requirements for mechanical resistance and stability and safety in use in the sense of the Basic Requirements 1 and 4 of Regulation (EU) 305/2011 shall be fulfilled and failure of anchorages made with these products would compromise the stability of the works, cause risk to human life and/or lead to considerable economic consequences.

Anchors subject to:

Static and quasi-static loads: sizes from M8 to M24.

Base material:

- Reinforced or unreinforced normal weight concrete of strength class C20/25 at minimum to C50/60 at maximum according to EN 206-1.
- Non cracked concrete: sizes from M8 to M24.
- Cracked concrete: sizes from M10 to M20.

Temperature range:

The anchors may be used in the following temperature range:

- -40°C to +40°C (max. short term temperature +40°C and max. long term temperature +24°C).
- -40°C to +80°C (max. short term temperature +80°C and max. long term temperature +50°C).
- -40°C to +120°C (max. short term temperature +120°C and max. long term temperature +72°C).

Use conditions (environmental conditions):

- Elements made of galvanized steel may be used in structures subject to dry internal conditions.
- Elements made of stainless steel may be used in structures subject to dry internal conditions and also in concrete subject to external atmospheric exposure (including industrial and marine environment) or exposure in permanently damp internal conditions if no particular aggressive conditions exist. Such particular aggressive conditions are e.g. permanent, alternating immersion in seawater or the splash zone of seawater, chloride atmosphere of indoor swimming pools or atmosphere with extreme chemical pollution (e.g. in desulphurization plants or road tunnels where de-icing materials are used).
- Elements made of high corrosion resistant steel may be used in structures subject to dry internal conditions and also in concrete subject to external atmospheric exposure or exposure in permanently damp internal conditions or in other particular aggressive conditions. Such particular aggressive conditions are e.g. permanent, alternating immersion in seawater or the splash zone of seawater, chloride atmosphere of indoor swimming pools or atmosphere with chemical pollution (e.g. in desulphurization plants or road tunnels where de-icing materials are used).

Installation:

- Dry or wet concrete (use category 1): sizes from M8 to M24.
- Flooded holes with the exception of seawater (use category 2): sizes from M8 to M24.
- All the diameters may be used overhead: sizes from M8 to M24.
- The anchors are suitable for hammer drilled holes: sizes from M8 to M24.

Design methods:

EOTA Technical Report TR029 (September 2010) or CEN/TS 1992-4.

Q-MULTIFIX B15, Q-MULTIFIX B15 W and Q-MULTIFIX B15 T	Annex B1 of European Technical Assessment ETA-15/0323
Intended use	

Table B1: Installation data

Size		M8	M10	M12	M16	M20	M24
Nominal drilling diameter	d_0 [mm]	10	12	14	18	24	28
Maximum diameter hole in the fixture	d_{fix} [mm]	9	12	14	18	22	26
Effective embedment depth	$h_{ef,min}$ [mm]	60	70	80	100	120	145
	$h_{ef,max}$ [mm]	160	200	240	320	400	480
Depth of the drilling hole	h_1 [mm]	$h_{ef} + 5$ mm					
Minimum thickness of the concrete slab	h_{min} [mm]	$h_{ef} + 30$ mm; ≥ 100 mm			$h_{ef} + 2d_0$		
Torque moment	T_{inst} [N·m]	10	20	40	80	130	200
Thickness to be fixed	$t_{fix,min}$ [mm]	> 0					
	$t_{fix,max}$ [mm]	< 1500					
Minimum spacing	s_{min} [mm]	40	40	40	50	60	80
Minimum edge distance	c_{min} [mm]	40	40	40	50	60	80

Q-MULTIFIX B15, Q-MULTIFIX B15 W and Q-MULTIFIX B15 T

Installation data

Annex B2
of European
Technical Assessment
ETA-15/0323

Table B2: Processing time and minimum curing time

Q-MULTIFIX B15 (standard version)		
Concrete temperature [C°]	Processing time [min.]	Minimum curing time¹⁾ [min.]
-10	105	1320
-5	65	780
0	45	420
+5	25	90
+10	16	60
+15	11,5	45
+20	7,5	40
+25	5	35
+30	3	30
+35	2	25
+40	1	20

Q-MULTIFIX B15 W (version for winter season)		
Concrete temperature [C°]	Processing time [min.]	Minimum curing time¹⁾ [min.]
-20	120	1440
-15	90	1000
-10	60	600
-5	40	210
0	25	100
+5	15	70
+10	10	50
+15	7	35
+20	5	30

Q-MULTIFIX B15 T (version for summer season)		
Concrete temperature [C°]	Processing time [min.]	Minimum curing time¹⁾ [min.]
+20	14	60
+25	11	50
+30	8	40
+35	6	30
+40	4	20
+45	3	20
+50	2	20

¹⁾ The minimum time from the end of the mixing to the time when the anchor may be torque or loaded (whichever is longer). Minimum resin temperature for installation +5°C; maximum resin temperature for installation +30°C. For wet condition and flooded holes the curing time must be double.

Q-MULTIFIX B15, Q-MULTIFIX B15 W and Q-MULTIFIX B15 T	Annex B3 of European Technical Assessment ETA-15/0323
Processing time and curing time	

Manual Blower pump: nominal dimensions

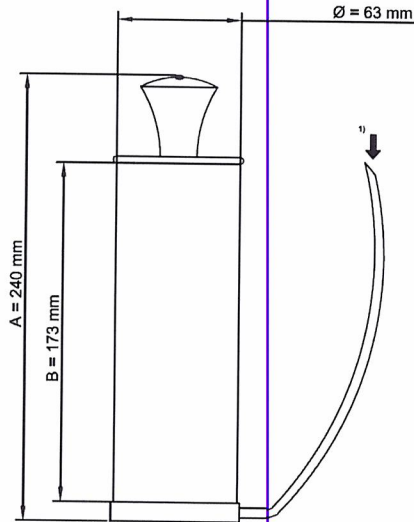

It is possible to use the mixer extensor with the manual blower pump.

However it is possible to blow the hole using the mechanical air system (compressed air) also with the mixer extension

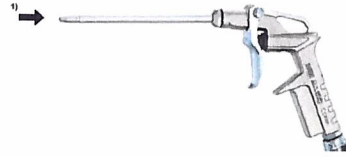

Suitable min pressure 6 bar at 6 m³/h
 Oil-free compressed air
 Recommended air gun with an orifice opening of minimum 3.5 mm in diameter

1) Position to Insert the mixer extension



Mixer extension (from 380 mm to 1000 mm) with nominal diameter 8 mm

Q-MULTIFIX B15, Q-MULTIFIX B15 W and Q-MULTIFIX B15 T

Cleaning tools (1)

Annex B4
 of European
 Technical Assessment
 ETA-15/0323

Table B3: Standard brush diameter

Threaded rod diameter			M8	M10	M12	M16	M20	M24
d_0	Nominal drill hole	[mm]	10	12	14	18	24	28
d_b	Brush diameter	[mm]	12	14	16	20	26	30

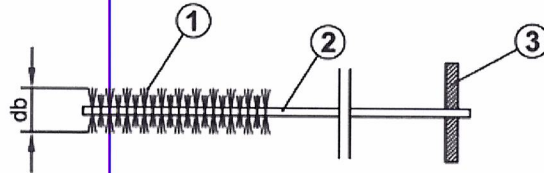

- ① Steel bristles
- ② Steel stem
- ③ Wood handle

Table B4: Special brush diameter (mechanical brush)

Threaded rod diameter			M16	M20	M24
d_0	Nominal drill hole	[mm]	18	24	28
d_b	Brush diameter	[mm]	20	26	30

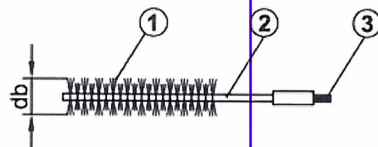

- ① Steel bristles
- ② Steel stem
- ③ Threaded connection for drilling tool extension
- ④ Extension special brush
- ⑤ Drilling tool connection (SDS connection)

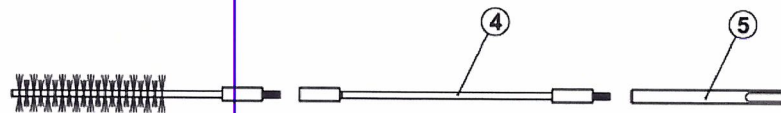

Q-MULTIFIX B15, Q-MULTIFIX B15 W and Q-MULTIFIX B15 T

Cleaning tools (2)

Annex B5
of European
Technical Assessment
ETA-15/0323

Use the mixer extension (assembled on the standard mixer) for the injection up to 300 mm if necessary.

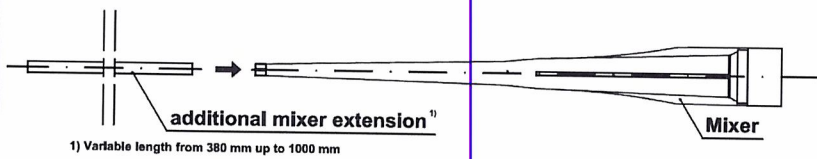

Use this system for special conditions.

Tools for installation in special condition

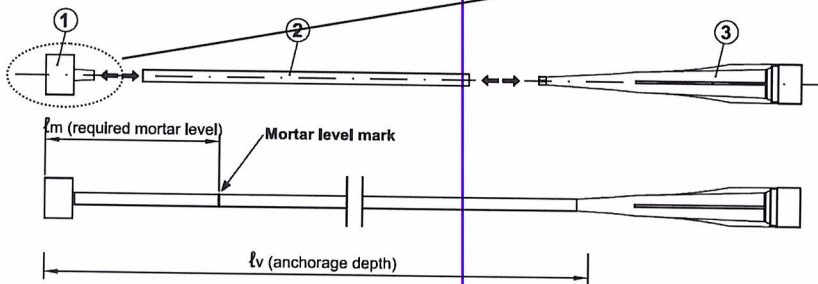

- ① Injection plug (nominal diameter according to the nominal diameter of drilled hole)
- ② Special mixer extension (variable length with external diameter 10 mm)
Mark the required mortar level l_m and embedment depth l_v with tape or marker on the injection extension. Quick estimation: $l_m = 1/3 \cdot l_v$
Continue injection until the mortar level mark l_m becomes visible.
- ③ Mixer (suitable for all size of cartridge)

These tools allow the application in special conditions:

- Installation with anchorage depth greater than 300 mm;
- overhead installation.

For these applications is recommended the use of the injection pneumatic pump.

System assembled

- ① Injection plug
- ② Special mixer extension
- ③ Mixer
- ④ cartridge
- ⑤ Sample of Injection pneumatic pump

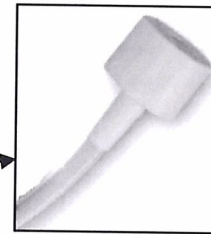
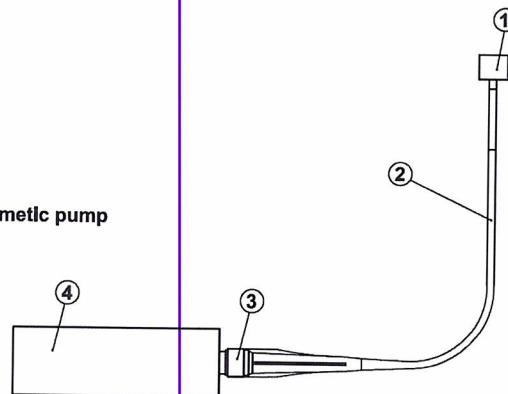
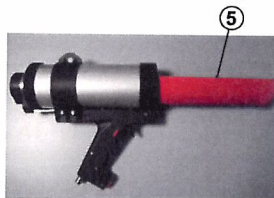

Insert the special mixer extension in the inner diameter of the injection plug up to reach the top of the plug

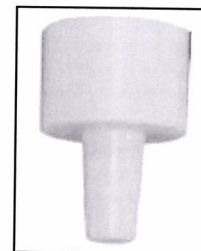
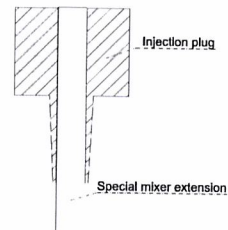

Q-MULTIFIX B15, Q-MULTIFIX B15 W and Q-MULTIFIX B15 T

Tools for injection (1)

Annex B6
of European
Technical Assessment
ETA-15/0323

Table B5: Mortar injection pumps

Pumps (injection guns)	Cartridges	Types
	300 ml 165 ml	Manual (up to 300 mm anchorage depth)
	345 ml 300 ml 165 ml	Manual (up to 300 mm anchorage depth)
	from 380 ml to 420 ml	Manual (up to 300 mm anchorage depth)
	from 380 ml to 420 ml	Pneumatic
	825 ml	Manual (up to 300 mm anchorage depth)
	825 ml	Pneumatic

Q-MULTIFIX B15, Q-MULTIFIX B15 W and Q-MULTIFIX B15 T

Tools for injection (2)

Annex B7
of European
Technical Assessment
ETA-15/0323

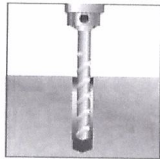
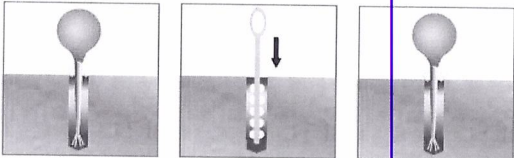
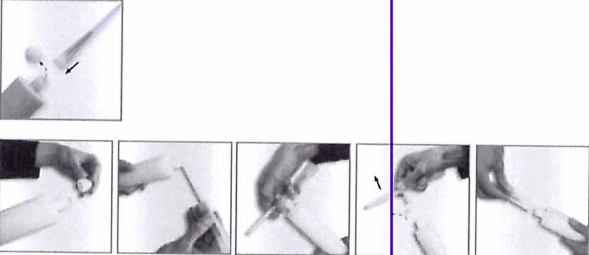
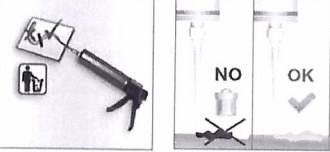
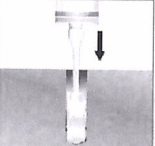
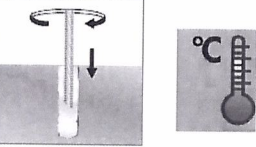
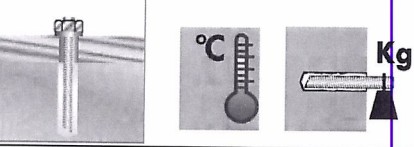
1		<p>Drill the hole with the correct diameter and depth using a rotary percussive machine (hammer drill). Check the perpendicularity of the hole during the drilling operation.</p>
2	 <p>4x 4x 4x</p>	<p>Clean the hole from the drilling dust: the hole shall be cleaned by at least four blowing operations, by at least four brushing operations followed again by at least four blowing operations; before brushing clean the brush and check (according to Annex B5) if the brush diameter is sufficient. For the blower tools see Annex B4.</p>
3		<p>For coaxial and side by side cartridge unscrew the front cup, screw on the mixer and insert the cartridge in the injection gun. For the CIC cartridges, unscrew the front cup, pull-out the steel closing clip according to the following operations:</p> <ul style="list-style-type: none"> - insert the mixer in the eye of the plastic extractor, - pull the extractor to unhook the steel closing clip of the foil. After that, screw on the mixer and insert the cartridge in the gun. Proper extrusion system according to Annex B7.
4		<p>Before starting to use the cartridge, eject a first part of the product, being sure that the two components are completely mixed. The complete mixing is reached only after that the product, obtained by mixing the two component, comes out from the mixer with an uniform color. Proper extrusion system according to Annex B7.</p>
5	 <p>if necessary use a mixer extension for the injection (see Annex B6)</p>	<p>Fill the drilled hole uniformly starting from the drilled hole bottom, in order to avoid entrapped air; remove the mixer slowly bit by bit during pressing-out; filling the drill hole with a quantity of the injection mortar corresponding to 2/3 of the drill hole depth.</p>
6	 <p>ATTENTION: Use the rods dry and free oil and other contaminants</p>	<p>Insert immediately the threaded rod, marked according to Annex A2, slowly and with a slight twisting motion, removing excess of injection mortar around the rod. Observe the processing time according to Annex B3.</p>
7		<p>Wait the curing time according to Annex B3. After that attach the fixture and tighten the nut to the required torque moment according to Annex B2.</p>
<p>Q-MULTIFIX B15, Q-MULTIFIX B15 W and Q-MULTIFIX B15 T</p>		<p>Annex B8 of European Technical Assessment ETA-15/0323</p>
<p>Installation instruction up to 300 mm depth</p>		

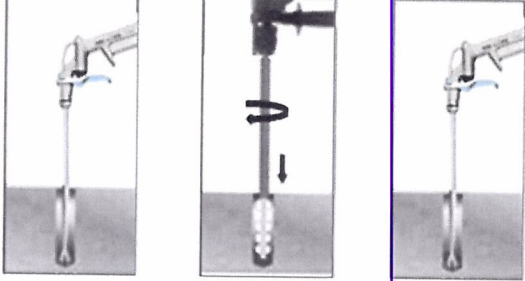
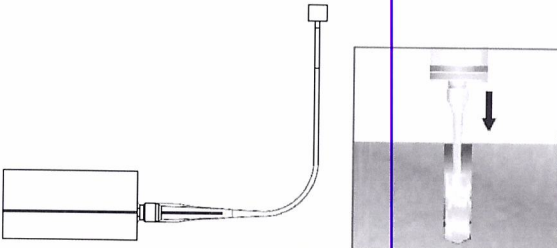
1	See point 1 Annex B8
2	<div style="display: flex; align-items: center;">  <div style="margin-left: 20px;"> <p>4 x 5 seconds 4x 4 x 5 seconds</p> <p>ATTENTION: compressed air free oil</p> </div> </div> <p>Clean the hole from the drilling dust: the hole shall be cleaned by at least four blowing operations, by at least four brushing operations followed again by at least four blowing operations; before brushing clean the brush and check (according to Annex B5) if the brush diameter is sufficient. For the blower tools see Annex B4.</p>
3	See point 3 Annex B8
4	See point 4 Annex B8
5	<div style="display: flex; align-items: center;">  <div style="margin-left: 20px;"> <p>Before starting the injection, assemble the system according to Annex B6. After that, fill the drilled hole uniformly from the drilled hole bottom, in order to avoid entrapment of the air; remove the special mixer extension with injection plug slowly bit by bit during pressing-out; filling the drill hole with a quantity of the injection mortar corresponding to 2/3 of the drill hole depth.</p> <p>Procedure for overhead installation are detailed in Annex B10.</p> </div> </div>
6	See point 6 Annex B8
7	See point 7 Annex B8
<p>Q-MULTIFIX B15, Q-MULTIFIX B15 W and Q-MULTIFIX B15 T</p>	
<p>Installation instruction up to 480 mm depth</p>	
<p>Annex B9 of European Technical Assessment ETA-15/0323</p>	

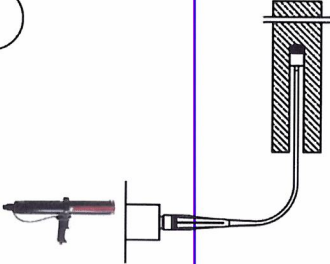
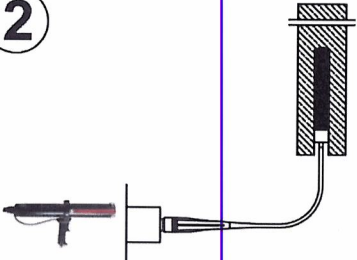
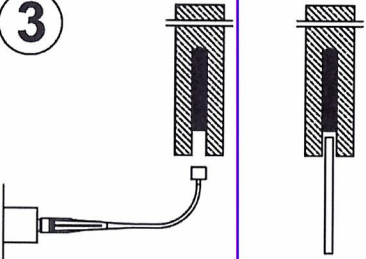
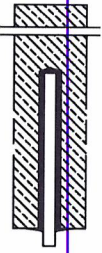
<p>1</p> 	<p>1 - Start injection</p> <p>Inject from the bottom of the hole. Maintain this position during the injection phase.</p>
<p>2</p> 	<p>2 - Injection phase</p> <p>Inject the product about 2/3 of the hole depth. During the injection maintain this position to assure the correct installation</p>
<p>3</p> 	<p>3 - End injection</p> <p>Remove the injection plug. Insert immediately the rod (turn the rod during the insertion).</p>
<p>4</p> 	<p>4 - End installation</p> <p>To avoid the slipping of the rod during the open time of the product (due to the rod own weight) use a temporary interlocking element (for ex. wedge of wood)</p>

Q-MULTIFIX B15, Q-MULTIFIX B15 W and Q-MULTIFIX B15 T

Overhead installation instruction

Annex B10
of European
Technical Assessment
ETA-15/0323

Table C1: Characteristic values for tension load in non cracked concrete

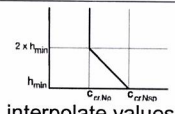
Size			M8	M10	M12	M16	M20	M24
Steel failure								
Steel failure with threaded rod grade 4.8								
Characteristic resistance	$N_{Rk,s}$	[kN]	15	23	34	63	98	141
Partial safety factor	γ_{Ms}	[-]	1,50					
Steel failure with threaded rod grade 5.8								
Characteristic resistance	$N_{Rk,s}$	[kN]	18	29	42	78	122	176
Partial safety factor	γ_{Ms}	[-]	1,50					
Steel failure with threaded rod grade 8.8								
Characteristic resistance	$N_{Rk,s}$	[kN]	29	46	67	126	196	282
Partial safety factor	γ_{Ms}	[-]	1,50					
Steel failure with threaded rod grade 10.9								
Characteristic resistance	$N_{Rk,s}$	[kN]	37	58	84	157	245	353
Partial safety factor	γ_{Ms}	[-]	1,40					
Steel failure with threaded rod grade 12.9								
Characteristic resistance	$N_{Rk,s}$	[kN]	44	70	101	188	294	424
Partial safety factor	γ_{Ms}	[-]	1,40					
Steel failure with stainless steel threaded rod A4-70								
Characteristic resistance	$N_{Rk,s}$	[kN]	26	41	59	110	171	247
Partial safety factor	γ_{Ms}	[-]	1,87					
Steel failure with stainless steel threaded rod A4-80								
Characteristic resistance	$N_{Rk,s}$	[kN]	29	46	67	126	196	282
Partial safety factor	γ_{Ms}	[-]	1,60					
Steel failure with high corrosion resistant steel grade 70								
Characteristic resistance	$N_{Rk,s}$	[kN]	26	41	59	110	171	247
Partial safety factor	γ_{Ms}	[-]	1,87					
Combined pull-out and concrete cone failure in non cracked concrete C20/25								
Characteristic bond resistance temperature range -40°C / +40°C ¹⁾	$\tau_{Rk,ucr}$	[N/mm ²]	16,0	12,0	12,0	12,0	9,5	9,5
Characteristic bond resistance temperature range -40°C / +80°C ¹⁾	$\tau_{Rk,ucr}$	[N/mm ²]	11,0	8,5	8,5	8,5	7,0	7,0
Characteristic bond resistance temperature range -40°C / +120°C ¹⁾	$\tau_{Rk,ucr}$	[N/mm ²]	6,0	4,5	4,5	4,5	4,0	4,0
Increasing factor for C30/37	ψ_c	[-]	1,12					
Increasing factor for C40/50			1,23					
Increasing factor for C50/60			1,30					
Splitting failure								
Edge distance	$C_{cr,Nsp}$	[mm]	If $h = h_{min}$					
			$2,5 \cdot h_{ef}$		$2,0 \cdot h_{ef}$		$1,5 \cdot h_{ef}$	
			If $h_{min} < h < 2 \cdot h_{min}$					
			 interpolate values					
Spacing	$S_{cr,Nsp}$	[mm]	if $h \geq 2 \cdot h_{min}$					
			$C_{cr,Np}$					
Partial safety factor for combined pull-out, concrete cone and splitting failure								
Partial safety factors for in use category 1 ($\gamma_2 = 1,0$ included)	$\gamma_{Mp} = \gamma_{Mc} = \gamma_{Msp}$ ²⁾	[-]	1,50					
Partial safety factors for in use category 2 ($\gamma_2 = 1,2$ included)			1,80					

Note: Design method according to TR 029

¹⁾ See: Annex B1 ²⁾ In the absence of other national regulation

Q-MULTIFIX B15, Q-MULTIFIX B15 W and Q-MULTIFIX B15 T

Characteristic resistance under tension loads
in non cracked concrete

Annex C1
of European
Technical Assessment
ETA-15/0323

Table C2: Characteristic values for tension loads in cracked concrete

Size			M10	M12	M16	M20
Steel failure						
Steel failure with threaded rod grade 4.8						
Characteristic resistance	$N_{Rk,s}$	[kN]	23	34	63	98
Partial safety factor	γ_{Ms}	[-]	1,50			
Steel failure with threaded rod grade 5.8						
Characteristic resistance	$N_{Rk,s}$	[kN]	29	42	78	122
Partial safety factor	γ_{Ms}	[-]	1,50			
Steel failure with threaded rod grade 8.8						
Characteristic resistance	$N_{Rk,s}$	[kN]	46	67	126	196
Partial safety factor	γ_{Ms}	[-]	1,50			
Steel failure with threaded rod grade 10.9						
Characteristic resistance	$N_{Rk,s}$	[kN]	58	84	157	245
Partial safety factor	γ_{Ms}	[-]	1,40			
Steel failure with threaded rod grade 12.9						
Characteristic resistance	$N_{Rk,s}$	[kN]	70	101	188	294
Partial safety factor	γ_{Ms}	[-]	1,40			
Steel failure with stainless steel threaded rod A4-70						
Characteristic resistance	$N_{Rk,s}$	[kN]	41	59	110	171
Partial safety factor	γ_{Ms}	[-]	1,87			
Steel failure with stainless steel threaded rod A4-80						
Characteristic resistance	$N_{Rk,s}$	[kN]	46	67	126	196
Partial safety factor	γ_{Ms}	[-]	1,60			
Steel failure with high corrosion resistant steel grade 70						
Characteristic resistance	$N_{Rk,s}$	[kN]	41	59	110	171
Partial safety factor	γ_{Ms}	[-]	1,87			
Combined pull-out and concrete cone failure in cracked concrete C20/25						
Characteristic bond resistance temperature range -40°C / +40°C ¹⁾	$\tau_{Rk,cr}$	[N/mm ²]	9,0	9,0	9,0	6,5
Characteristic bond resistance temperature range -40°C / +80°C ¹⁾	$\tau_{Rk,cr}$	[N/mm ²]	6,5	6,5	6,5	4,5
Characteristic bond resistance temperature range -40°C / +120°C ¹⁾	$\tau_{Rk,cr}$	[N/mm ²]	3,5	3,5	3,5	2,5
Increasing factor for C30/37	ψ_c	[-]	1,12			
Increasing factor for C40/50			1,23			
Increasing factor for C50/60			1,30			
Splitting failure						
Edge distance	$C_{cr,Nsp}$	[mm]	If $h = h_{min}$			
			$2,5 \cdot h_{ef}$	$2,0 \cdot h_{ef}$	$1,5 \cdot h_{ef}$	
			If $h_{min} < h < 2 \cdot h_{min}$			
			interpolatē vārties			
Spacing	$S_{cr,Nsp}$	[mm]	if $h \geq 2 \cdot h_{min}$			
			$C_{cr,Np}$			
			$2 \cdot C_{cr,sp}$			
Partial safety factor for combined pull-out, concrete cone and splitting failure						
Partial safety factors for in use category 1 ($\gamma_2 = 1,0$ included)	$\gamma_{Mp} = \gamma_{Mc} = \gamma_{Msp}$ ²⁾	[-]	1,50			
Partial safety factors for in use category 2 ($\gamma_2 = 1,2$ included)			1,80			

Note: Design method according to TR 029

¹⁾ See: Annex B1 ²⁾ In the absence of other national regulation

Q-MULTIFIX B15, Q-MULTIFIX B15 W and Q-MULTIFIX B15 T

Characteristic resistance under tension loads
in cracked concrete

Annex C2
of European
Technical Assessment
ETA-15/0323

Table C3: Characteristic values for shear loads - steel failure without lever arm

Size			M8	M10	M12	M16	M20	M24
Steel failure with threaded rod grade 4.8								
Characteristic resistance	$V_{Rk,s}$	[kN]	7	12	17	31	49	71
Partial safety factor ¹⁾	γ_{Ms}	[-]	1,25					
Steel failure with threaded rod grade 5.8								
Characteristic resistance	$V_{Rk,s}$	[kN]	9	14	21	39	61	88
Partial safety factor ¹⁾	γ_{Ms}	[-]	1,25					
Steel failure with threaded rod grade 8.8								
Characteristic resistance	$V_{Rk,s}$	[kN]	15	23	34	63	98	141
Partial safety factor ¹⁾	γ_{Ms}	[-]	1,25					
Steel failure with threaded rod grade 10.9								
Characteristic resistance	$V_{Rk,s}$	[kN]	18	29	42	78	122	176
Partial safety factor ¹⁾	γ_{Ms}	[-]	1,50					
Steel failure with threaded rod grade 12.9								
Characteristic resistance	$V_{Rk,s}$	[kN]	22	35	51	94	147	212
Partial safety factor ¹⁾	γ_{Ms}	[-]	1,50					
Steel failure with stainless steel threaded rod A4-70								
Characteristic resistance	$V_{Rk,s}$	[kN]	13	20	29	55	86	124
Partial safety factor ¹⁾	γ_{Ms}	[-]	1,56					
Steel failure with stainless steel threaded rod A4-80								
Characteristic resistance	$V_{Rk,s}$	[kN]	15	23	34	63	98	141
Partial safety factor ¹⁾	γ_{Ms}	[-]	1,33					
Steel failure with high corrosion stainless steel grade 70								
Characteristic resistance	$V_{Rk,s}$	[kN]	13	20	29	55	86	124
Partial safety factor ¹⁾	γ_{Ms}	[-]	1,56					

Table C4: Characteristic values for shear loads - steel failure with lever arm

Size			M8	M10	M12	M16	M20	M24
Steel failure with threaded rod grade 4.8								
Characteristic resistance	$M^0_{Rk,s}$	[Nm]	15	30	52	133	260	449
Partial safety factor ¹⁾	γ_{Ms}	[-]	1,25					
Steel failure with threaded rod grade 5.8								
Characteristic resistance	$M^0_{Rk,s}$	[Nm]	19	37	65	166	324	561
Partial safety factor ¹⁾	γ_{Ms}	[-]	1,25					
Steel failure with threaded rod grade 8.8								
Characteristic resistance	$M^0_{Rk,s}$	[Nm]	30	60	105	266	519	898
Partial safety factor ¹⁾	γ_{Ms}	[-]	1,25					
Steel failure with threaded rod grade 10.9								
Characteristic resistance	$M^0_{Rk,s}$	[Nm]	37	75	131	333	649	1123
Partial safety factor ¹⁾	γ_{Ms}	[-]	1,50					
Steel failure with threaded rod grade 12.9								
Characteristic resistance	$M^0_{Rk,s}$	[Nm]	45	90	157	400	779	1347
Partial safety factor ¹⁾	γ_{Ms}	[-]	1,50					
Steel failure with stainless steel threaded rod A4-70								
Characteristic resistance	$M^0_{Rk,s}$	[Nm]	26	52	92	233	454	786
Partial safety factor ¹⁾	γ_{Ms}	[-]	1,56					
Steel failure with stainless steel threaded rod A4-80								
Characteristic resistance	$M^0_{Rk,s}$	[Nm]	30	60	105	266	519	898
Partial safety factor ¹⁾	γ_{Ms}	[-]	1,33					
Steel failure with high corrosion resistant steel grade 70								
Characteristic resistance	$M^0_{Rk,s}$	[Nm]	26	52	92	233	454	786
Partial safety factor ¹⁾	γ_{Ms}	[-]	1,56					

¹⁾ In the absence of other national regulation

Q-MULTIFIX B15, Q-MULTIFIX B15 W and Q-MULTIFIX B15 T

Characteristic resistance under shear loads
in cracked and non-cracked concrete

Annex C3
of European
Technical Assessment
ETA-15/0323

Table C5: Characteristic values for shear loads - pry out and concrete edge failure

Size			M8	M10	M12	M16	M20	M24
Effective anchorage depth h_{ef}	min	[mm]	60	70	80	100	120	145
	max	[mm]	160	200	240	320	400	480
Pry out failure								
Factor	k	[-]	2	2	2	2	2	2
Partial safety factor ¹⁾	γ_{Mp}	[-]	1,5					
Concrete edge failure								
Partial safety factor ¹⁾	γ_{Mc}	[-]	1,5					

¹⁾ In the absence of other national regulation

Table C6: Displacement under tension loads

Size			M8	M10	M12	M16	M20	M24
Characteristic displacement in non-cracked concrete C20/25 to C50/60 under tension loads								
Admissible service load*	F	[kN]	9,6	10,8	14,3	23,8	29,6	42,4
Displacement	δ_{No}	[mm]	0,30	0,30	0,35	0,35	0,35	0,40
	δ_{Nc}	[mm]	0,85	0,85	0,85	0,85	0,85	0,85

Size			M10	M12	M16	M20
Characteristic displacement in cracked concrete C20/25 to C50/60 under tension loads						
Admissible service load*	F	[kN]	9,5	14,3	21,4	23,8
Displacement	δ_{No}	[mm]	0,50	0,50	0,70	0,60
	δ_{Nc}	[mm]	0,85	0,85	0,85	0,85

* These values are suitable for each temperature range and categories specified in Annex B1

Table C7: Displacement under shear loads

Size			M8	M10	M12	M16	M20	M24
Characteristic displacement in cracked and non-cracked concrete C20/25 to C50/60 under shear loads								
Admissible service load*	F	[kN]	3,7	5,8	8,4	15,7	24,5	35,3
Displacement	δ_{Vo}	[mm]	2,0	2,0	2,0	2,0	2,0	2,0
	δ_{Vc}	[mm]	3,0	3,0	3,0	3,0	3,0	3,0

* These values are suitable for each temperature range and categories specified in Annex B1

Q-MULTIFIX B15, Q-MULTIFIX B15 W and Q-MULTIFIX B15 T

Characteristic resistance under shear loads.
Displacement under service loads: tension and shear loads

Annex C4
of European
Technical Assessment
ETA-15/0323